

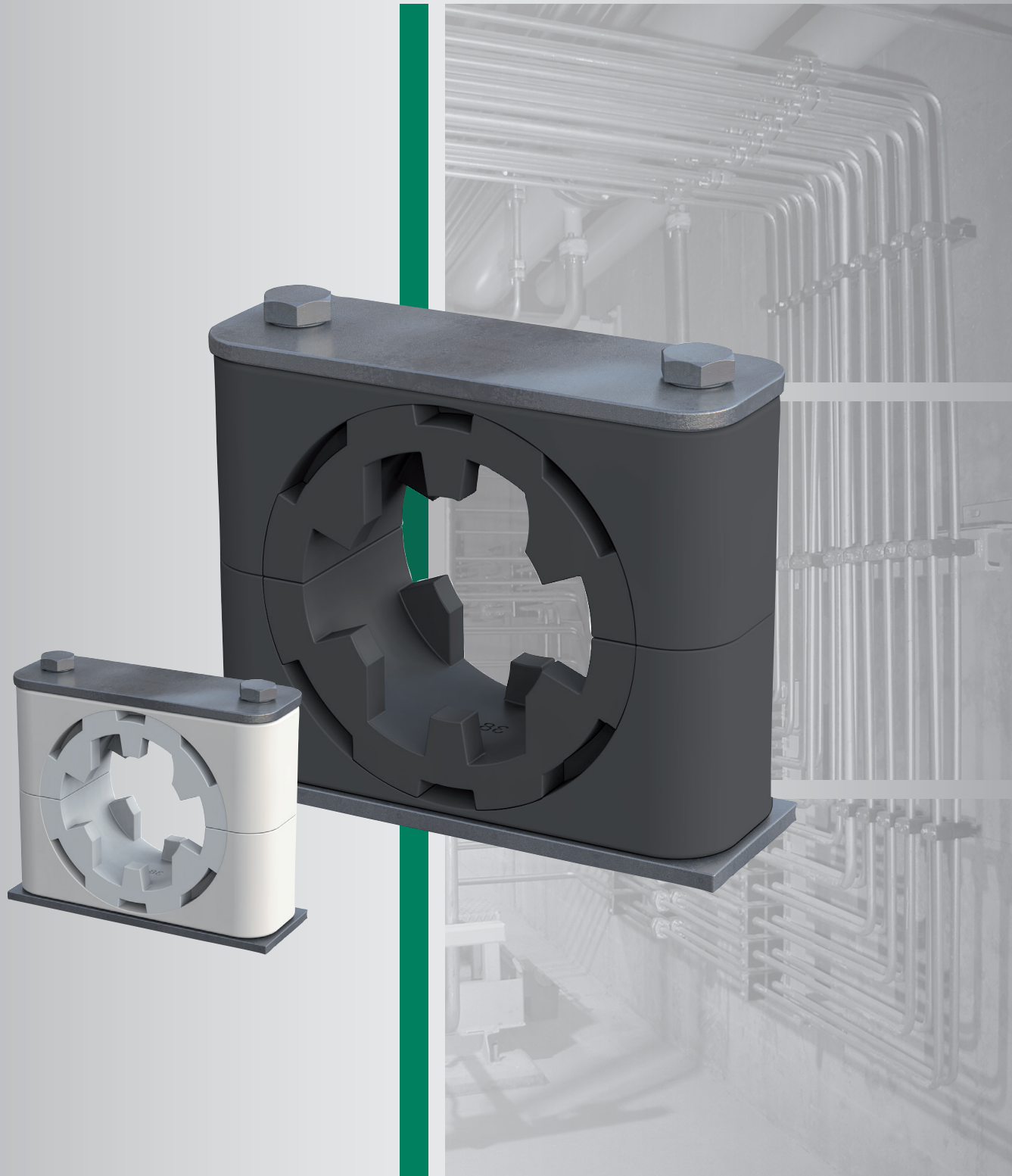

Local Solutions For Individual Customers Worldwide



Noise and Vibration Damping with STAUFF NRC Noise Reduction Clamps

Product Catalogue

Noise and Vibration Damping with STAUFF NRC Noise Reduction Clamps

Product Description

STAUFF NRC type clamps were designed for the noise and vibration reducing installation of pipes and tubes with the most common outside diameters between 6 and 42 mm and ¼ to 1 ½ inch respectively.

The working principle is based on clamp bodies ① made from Polypropylene (colour: black) following the Standard Series according to DIN 3015 (part 1) with a specially shaped, two-part elastomer insert ②, which mechanically absorbs vibrations in the pipe and as a result reduces noises arising to a minimum.

The insert is in particular distinguished by how little of its surface is in contact with the pipe and clamp body, and as a result is far more effective than the previously known solutions.

The tongue-groove contour of the insert and body, which is reversed and thus diverges from DIN 3015, enables the system to be used for the widest possible range of pipe diameters per clamp size, which contributes to flexibility and versatility.

STAUFF NRC Clamps are completely compatible with the commonly used steel and stainless steel mounting hardware ③, and if necessary can simply be replaced or retrofitted.

STAUFF also provides an alternative version ④ especially for use in safety-critical areas, which is made completely out of flame resistant materials according to international standards and directives, and meets the demanding requirements with regards to preventive fire protection.

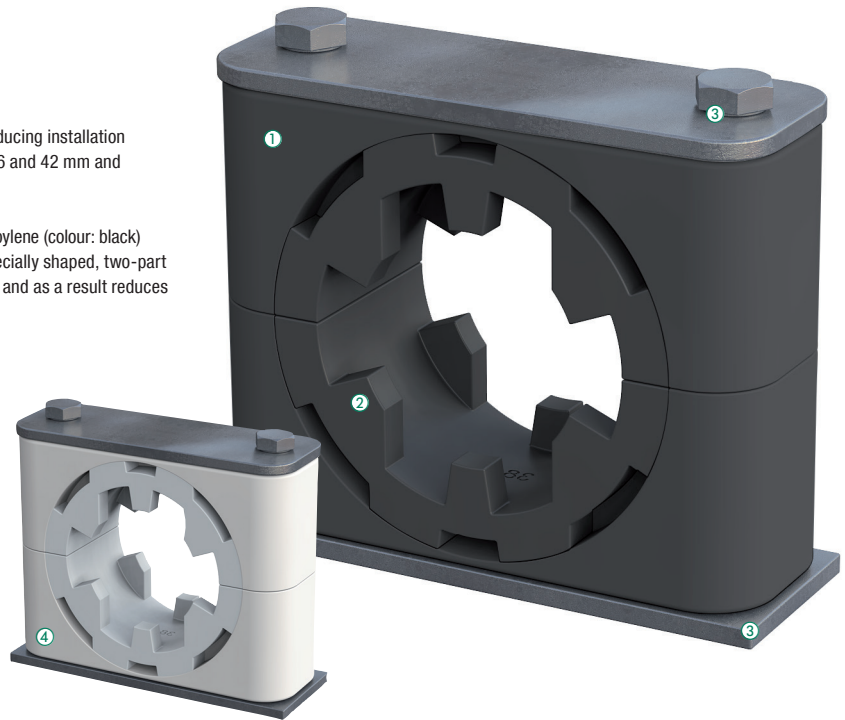

Typical Applications

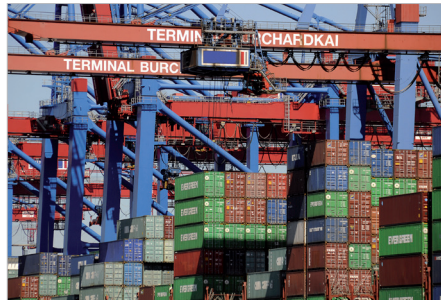

Mobile and stationary machines in harbour and loading areas as well as municipal and commercial vehicles

- Reducing the overall level of noise emissions, especially in urban areas
- Improving occupational health and safety
- Contributing to build machinery that conforms to the Machinery Directive 2006/42/EC and the Outdoor Directive 2000/14/EC of the European Parliament and of the Council



Civil shipping, i.e. on cruise ships as well as yachts and sport boats

- Maximising flexibility with the design, layout and positioning of noise-intensive pipes and tubes (e.g. in close proximity to cabins or crew quarters)
- Making a great contribution to comfort and facilitating communication on board (e.g. for engine and control rooms)
- Reducing of underwater noise in order to protect the maritime environment

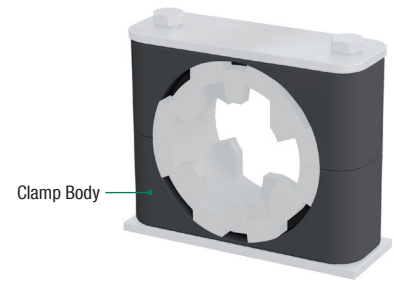
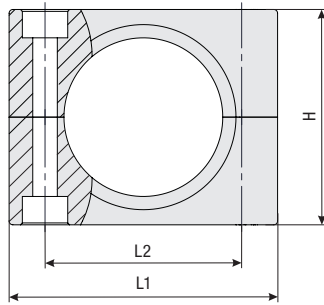
Clamp Body - Type PP-NRC

Group	STAUFF	DIN	Dimensions (mm/in)			Width	Order Codes Clamp Body (2 Halves)
			L1	L2	H		
2		2	42	26	32	30	2-PP-NRC
			1.65	1.02	1.26		
3		3	50	33	35,5	30	3-PP-NRC
			1.97	1.30	1.40		
4		4	59	40	41,5	30	4-PP-NRC
			2.32	1.57	1.63		
5		5	71	52	56,5	30	5-PP-NRC
			2.80	2.05	2.22		
6		6	86	66	64,5	30	6-PP-NRC
			3.39	2.60	2.54		

Order Codes

NRC Clamp Body ***2-*PP-NRC**

* STAUFF Group **2**

* Material Polypropylene (Colour: Black) **PP-NRC**

One clamp body is consisting of two clamp halves.

Alternative materials and colours are available on request.
Please consult STAUFF for further information.

Standard packaging unit: 25 clamp bodies per bag (equals 50 clamp halves).

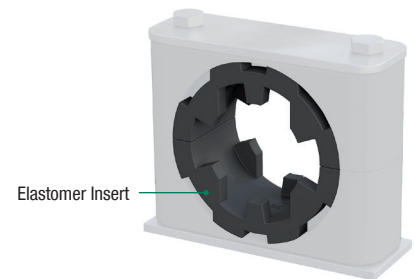
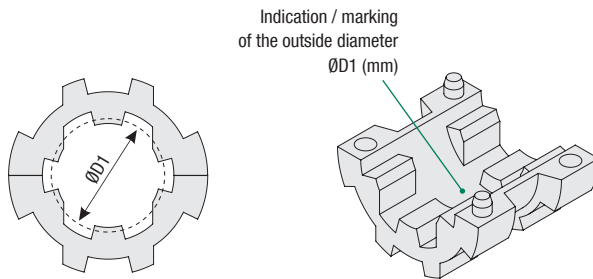
Elastomer Insert - Type RI-NRC

Group	STAUFF	DIN	Outside diameter Pipe / Tube ØD1		Nominal Bore		Copper tube ASTM B88 (in)	Order Codes Elastomer Insert (2 Halves)
			(mm)	(in)	Pipe (in)			
2		2	6					RI-NRC-6-2
			8		5/16			RI-NRC-8-2
			10			1/8		RI-NRC-10-2
			12					RI-NRC-12-2
			12,7		1/2			RI-NRC-12.7-2
3		3	14					RI-NRC-14-3
			15					RI-NRC-15-3
			16		5/8		1/2	RI-NRC-16-3
4		4	18					RI-NRC-18-4
			20					RI-NRC-20-4
5		5	21,3			1/2		RI-NRC-21.3-5
			22				3/4	RI-NRC-22-5
			25					RI-NRC-25-5
			26,9			3/4		RI-NRC-26.9-5
			28					RI-NRC-28-5
			30					RI-NRC-30-5
6		6	32		1-1/4			RI-NRC-32-5
			33,7			1		RI-NRC-33.7-6
			35				1-1/4	RI-NRC-35-6
			38		1-1/2			RI-NRC-38-6
			40					RI-NRC-40-6
			42		1-1/4		RI-NRC-42-6	

Order Codes

NRC Elastomer Insert ***RI-NRC-*6-*2**

* Elastomer Insert **RI-NRC**

* Exact outside diameter ØD1 (mm) **6**

* STAUFF Group **2**

One elastomer insert is consisting of two insert halves.

Standard material is Thermoplastic Elastomer
(Colour: Black) with a hardness degree of 73 Shore-A.
Alternative materials and colours are available on request.
Please consult STAUFF for further information.

Additional outside diameters are available upon request. Please consult STAUFF for further information.
Standard packaging unit: 25 elastomer inserts per bag (equals 50 insert halves).

STAUFF Bond

Adhesively Bonding Original STAUFF Pipe, Tube and Hose Clamps to Industrial Surfaces

STAUFF Bond offers increased flexibility in the initial assembly of machines and plants, and makes it possible to implement later changes, expansions or even repairs with comparatively little effort. This considerably reduces the processing times and costs that previously had to be factored in to the assembly process.

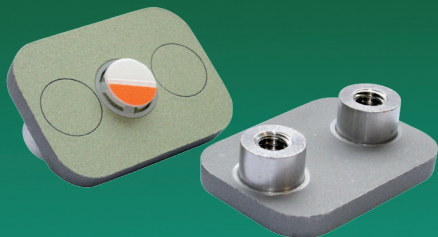

Eliminate Need
for Hot Work

Learn more at www.stauff.com/innovation



GERMANY

Walter Stauffenberg GmbH & Co. KG
Im Ehrenfeld 4 | 58791 Werdohl
Tel.: +49 23 92 916 0
Fax: +49 23 92 916 160
sales@stauff.com

Globally available through wholly-owned branches and distributors in all industrial countries.



www.stauff.com

AUSTRALIA

STAUFF Corporation Pty Ltd
Tel.: +61 2 4271 9000
sales@stauff.com.au

BRAZIL

STAUFF Brasil Ltda.
Tel.: +55 11 47 72 72 00
stauff@stauffbrasil.com

CHINA

STAUFF China
Tel.: +86 21 68 18 70 00
info@stauff.com.cn

FRANCE

STAUFF S.A.S.
Tel.: +33 2 54 50 55 50
direction@stauffsa.com

INDIA

STAUFF India Pvt. Ltd.
Tel.: +91 20 66 20 2466
sales@stauffindia.com

IRELAND

STAUFF Ireland
Tel.: +44 28 92 60 69 00
sales@stauffireland.com

ITALY

STAUFF Italia S.r.l.
Tel.: +39 031 65 84 94
sales@stauff.it

CANADA

STAUFF Canada Ltd.
Tel.: +1 416 282 46 08
sales@stauffcanada.com

KOREA

STAUFF Korea Ltd.
Tel.: +82 51 266 66 66
info@stauff.co.kr

MALAYSIA

STAUFF South East Asia Sdn Bhd
Tel.: +60 3 5637 7888
sales@stauff.com.my

NEW ZEALAND

STAUFF Corporation (NZ) Ltd.
Tel.: +64 9 271 48 12
sales@stauff.co.nz

POLAND

STAUFF Polska Sp. z o.o.
Tel.: +48 58 660 11 60
sales@stauff.pl

RUSSIAN FEDERATION

STAUFF LLC
Tel.: +7 495 276 16 50
sales@stauff.ru

THAILAND

STAUFF (Thailand) Co., Ltd.
Tel.: +66 2 721 73 23
sales@stauff.co.th

UNITED STATES

STAUFF Corporation
Tel.: +1 201 444 78 00
sales@stauffusa.com

UNITED KINGDOM

STAUFF UK Ltd.
Tel.: +44 114 251 85 18
sales@stauff.co.uk

VIETNAM

STAUFF Vietnam Ltd.
Tel.: +84 8 3948 1041
sales@stauff.com.vn

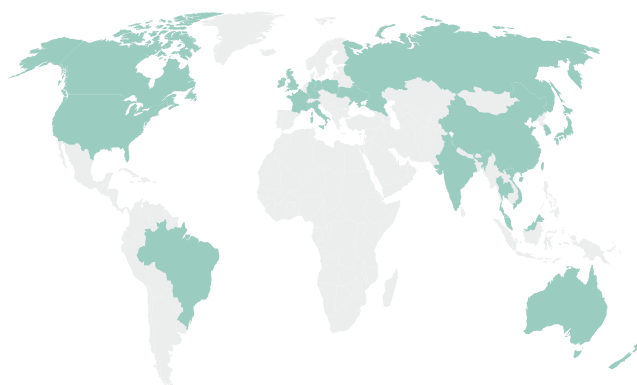

 facebook.com/stauffgroup

 twitter.com/stauffgroup

 youtube.com/stauffgroup